

Energy Management Energy Meter Type EM330

CARLO GAVAZZI



- Easy connection or wrong current direction detection
- Certified according to MID Directive (option PF only): see "how to order" below
- Compliant with the international accuracy standard IEC/EN62053-21, and the IEC/EN61557-12 performance requirements (active power and active energy).
- Other versions available (not certified, option X): see "how to order" on the next page

- Three phase energy meter
- Class 1 (kWh) according to EN62053-21
- Class B (kWh) according to EN50470-3
- Accuracy $\pm 0.5\%$ RDG (current/voltage)
- Current measurement via CT
- Backlit LCD display (3x 8-digit) with integrated touch key-pad
- Energy readout on display: 8 digit
- Variable readout on display: 4 digit
- Energy measurement: kWh and kvarh (imported/exported); kWh+ by 2 tariffs; kWh per phase
- System variables: kW, kvar, kVA, VLL, VLN, PF, Hz, kWdmd, kWdmd peak
- Phase variables: kW, kvar, kVA, VLL, VLN, A, PF
- Auxiliary power supply
- Dimensions: 3-DIN module
- Protection degree (front): IP51
- Pulse output (optional, by open collector PNP)
- RS485 Modbus port (optional)
- M-Bus port (optional)
- Run hour meter
- Neutral current calculation
- Digital input (for tariff management)

Product description

Three-phase energy meter with backlit LCD display with integrated touch keypad. Particularly indicated for active energy metering and for cost

allocation (CT connection), with dual tariff management availability. It can measure imported and exported energy or be programmed to consider

only the imported one. Housing for DIN-rail mounting, with IP51 front degree protection. The meter is optionally provided with pulse output proportional

to the active energy being measured, RS485 Modbus port or M-Bus port. Available for legal metrology (PF option, only for imported energy).

MID

Certified according to MID Directive, Module B and Module D of Annex II, for legal metrology relevant to active electrical energy meters (see Annex V, MI003, of MID). Can be used for fiscal (legal) metrology.

How to order

EM330 DIN AV5 3 H O1 PF B

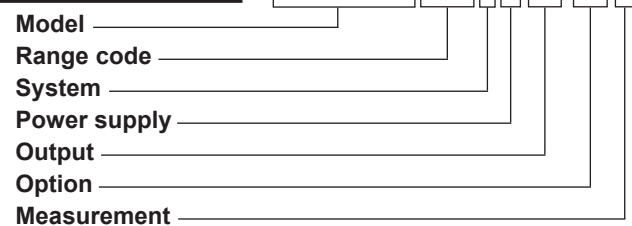

Type Selection

Range code	System	Power supply	Output
AV5: 400 VLL AC - 5(6)A (CT connection)	3: 3-phase, 3 or 4 wire	H: auxiliary power supply 100 to 240 V ac/dc	O1: pulse output S1: RS485 Modbus port M1: M-Bus port
Option	Measurement		
PF: Certified according to MID Directive. Can be used for fiscal (legal) metrology.	A: The power is always integrated (both in case of positive imported and negative exported power) and the total energy meter is certified according to MID. B: Only the total positive energy meter is certified according to MID.		



STANDARD

Not certified according to MID Directive. Cannot be used for fiscal (legal) metrology.

How to order **EM330 DIN AV5 3 H O1 X**

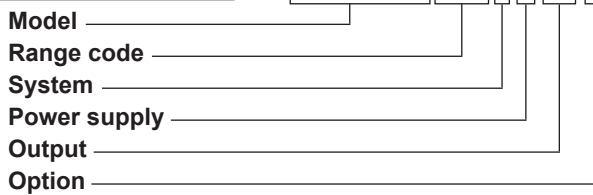

Type Selection

Range code	System	Power supply	Output
AV5: 400 to 480 VLL ac - 5(6)A (CT connection) 230 to 277 VLN ac - 5(6)A (CT connection)	3: 3-phase, 3- or 4-wire; 2-phase 3-wire, 1-phase 2 wire	H: auxiliary power supply 100 to 240V ac/dc	O1: pulse output S1: RS485 Modbus port M1: M-Bus port

Option

X: none

Input specifications

Rated Inputs			
Current type	3-phase loads, CT connection	Temperature drift	≤200ppm/°C
Current range	5(6)A	Sampling rate	4096 samples/s @ 50Hz 4096 samples/s @ 60Hz
Nominal voltage	AV5: 400 to 480 VLL ac	Display and touch key-pad	
Max CTxVT	AV5: 1000	Type	Backlit LCD, 3 rows by 8-digit each, h 7 mm
Accuracy (@25°C ±5°C, R.H. ≤60%, 45 to 65 Hz)		Read-out	
	AV5: Imin=0.25A; In: 5A, Imax: 6A; Un: 230 to 277 VLN (400 to 480 VLL)	Energy:	8 digit.
Current	From 0.04In to 0.2In: ±(0.5%RDG+1DGT) From 0.2In to Imax: ±(0.5%RDG)	Variables:	4 digit
Phase-neutral voltage	In the range Un: ±(0.5% RDG)	Touch key	3 (DOWN, Enter and UP).
Phase-phase voltage	In the range Un: ±(1% RDG)	Max. and Min. indication	
Frequency	From 45 to 65 Hz: ±(0.2% RDG).	Energies	Max. 99 999 999 Min. 0.01
Active power	From 0.05 In to Imax, within Un range, PF=1: ±(1% RDG) From 0.1 In to Imax, within Un range, PF=0.5L or 0.8C: ±(1% RDG)	Variables	Max. 9999 Min. 0.01
Power factor	±[0.001+1%(1.000 - "PF RDG")]	Memory	
Reactive power	From 0.05 In to Imax, within Un range, sinphi=1: ±(2% RDG) From 0.1 In to Imax, within Un range, sinphi=0.5L or 0.8C: ±(2% RDG)	Energy	10 ¹² cycles. Energy value is saved every time the less significant digit increases.
Energies		Programming parameters	10 ¹² cycles. When a parameter is modified, only the relevant memory cell is overwritten
Active energy	Class 1 according to EN62053-21 and Class B according to EN50470-3	LEDs	
Reactive energy	Class 2 according to EN62053-23	Flashing red light pulses	Proportional to the product of the CT and VT ratios
Start-up current:	10mA	Weight (pulses/kWh) 1	> 700,1 (CT x VT)
Start-up voltage	90VLN	Weight (pulses/kWh) 10	70.1–700 (CT x VT)
Resolution	Display	Weight (pulses/kWh) 100	7.1–70 (CT x VT)
Current	0.1 A	Weight (pulses/kWh) 1000	< 7.1 (CT x VT)
Voltage	0.1 V	Duration	90ms
Power	0.01 kW or kvar	Fix orange light	wrong current direction (only with PFB option or with "B" measurement selection in case of X option)
Frequency	0.1 Hz	Current overloads	
PF	0.01	Continuous	6A, @ 50Hz
Energies (positive)	0.01 kWh or kvarh	For 500ms	5 In
Energies (negative)	0.01 kWh or kvarh	Voltage Overloads	
Serial communication		Continuous	1.2 Un
Current	0.001 A	For 500ms	2 Un
Voltage	0.1 V	Input impedance	
Power	0.1 W or var	230VL-N	1.2 Mohm
Frequency	0.1Hz	5(6) A	< 0.072 VA per channel
PF	0.001	Wrong connection detection	Installation guide to indicate if connections are correctly carried out. Can be disabled.
Energies (positive)	0.001 kWh or kvarh	Phase sequence	Indicates if the phase sequence is not the correct one (L1-L2-L3)
Energies (negative)	0.001 kWh or kvarh	Correct current direction	Indicates if the current direction is not the right one (only with PFB option or with type "B" measurement selection in case of X

Input specifications (cont.)

Load conditions	option). The wrong connection detection works in case of loads with: - PF>0.766 (<40°) if inductive or PF>0.996 (<5°) if capacitive - a current at least equal to 10% rated current	energies with positive sign are summed to increase the total positive energy totalizer (kWh+), while the others increase the total negative totalizer (kWh-). Ex. P L1= +2kW, P L2 = +2kW, P L3 = -3 kW Integration time = 1 hour +kWh = (2+2) x1h = 4 kWh -kWh = 3 x 1h = 3kWh
Energy metering	in every measuring interval the single phase	

Digital input specifications

Digital inputs	Free of voltage contact	Contact resistance	≤1kohm, close contact
Function	Tariff management (switch between t1-t2)	Overload	≥100kohm, open contact
Number of inputs	1		In case a voltage is erroneously applied to the digital input, the input is not damaged up to 30 V ac/dc.
Contact measurement voltage	5 V		
Input impedance	1kohm		

Output specifications

RS485 serial port	RS485 by screw connection.	Meters in the M-Bus network	250
Function	For communication of measured data, programming parameters	Primary address	Selectable
Protocol	ModBus RTU (slave function)	Secondary address	Univocally defined in each unit
Baud rate	9.6, 19.2, 38.4, 57.6, 115.2 kbaud,	Identification number range	from 9000 0000 to 9999 9999
Data format	even or no parity,	Other	Available functions: wild card, header, initialisation
Address	1 to 247 (default: 01)		SND_NKE, and req_uds management. Management of primary address
Driver input capability	1/8 unit load. Maximum 247 devices on the same bus.		modification via M-Bus VIF, VIFE, DIF and DIFE: see protocol
Data refresh time	1s	Static output	
Read command	50 words available in 1 read command	Purpose	For pulse output proportional to the active energy (kWh)
Rx/Tx indication	Rx segment on display is shown when a valid Modbus command is sent to that specific meter Tx segment on display is shown when a valid Modbus reply is sent back to the master	Pulse rate (imp/kWh)	Selectable according to pulse ON duration (Ton) 1-1500 (Ton = 30 ms) 1-500 (Ton = 100 ms) Note: max CTxVT x pulse ratio 20000 (e.g.: if pulse ratio is set to 1000, CTxVT max = 20)
M-Bus port	M-Bus by screw connection.		
Function	For communication of measured data		
Protocol	M-Bus according to EN13757-1		
Baud rate	0.3, 2.4, 9.6 kbaud		

Output specifications

Weight (pulses/kWh) 1 Weight (pulses/kWh) 10 Weight (pulses/kWh) 100 Weight (pulses/kWh) 1000	Note 2: in MID models, the pulse rate is automatically set according to CT x VT ratio: > 700,1 (CT x VT) 70.1–700 (CT x VT) 7.1–70 (CT x VT) < 7.1 (CT x VT)	Pulse ON duration	Selectable: 30 ms or 100 ms according to EN62053-31 Open collector PNP V_{ON} 1 V dc max. 100mA V_{OFF} 80 V dc max.
		Output type	
		Load	

General specifications

Operating temperature	-25 to +65 °C (-13 to 149° F) (X option), -25 to +55 °C (-13 to 131 °F) (PF option), indoor, (R.H. from 0 to 90% non-condensing @ 40°C)	Standard compliance	EN62052-11 (X option models), EN50470-1 (PF option models) EN62053-21 (X option models), EN50470-3 (PF option models) IEC/EN61557-12 (active power and active energy, MID models only)
Storage temperature	-30°C to +80°C (-22 to 176° F) (R.H. < 90% non condensing @ 40°C)	Safety	
Overvoltage category	Cat. III	Metrology	
Insulation (for 1 minute)	4000 V ac RMS between measuring inputs and digital/serial output (see table) 4000 V ac RMS	Approvals	
Dielectric strength	4000 V ac RMS for 1 minute	Connections	Voltage inputs: max. 4 mm ² , min. 1 mm ² with/without metallic cable ferrule; Max. screw tightening torque: 0.6 Nm 1.5 mm ² , Min./Max. screws tightening torque: 0.4 Nm
EMC	According to EN62052-11 (X option models) According to EN50470-1 (PF option models)	Other terminals	
Immunity and emissions		Housing	54 x 90 x 63 mm Polycarbonate, self-extinguishing Included
		Dimensions (WxHxD)	
		Material	
		Sealing covers	Included
		Mounting	DIN-rail
		Protection degree	IP51 IP20
		Front	
		Screw terminals	
		Weight	Approx. 240 g (packing included)

Power supply specifications

Auxiliary power supply

H: 100 to 240 Vac/dc $\pm 10\%$

Power consumption

 $\leq 1W, \leq 8VA$

Insulation (for 1 minute) between inputs and outputs

	Measuring input	Digital or serial output	Digital input
Measuring input	-	4 kV	4 kV
Digital or serial output	4 kV	-	0 kV
Digital input	4 kV	0 kV	-

Accuracy (according to EN50470-3 and EN62053-23)

kWh, accuracy (RDG) depending on the current

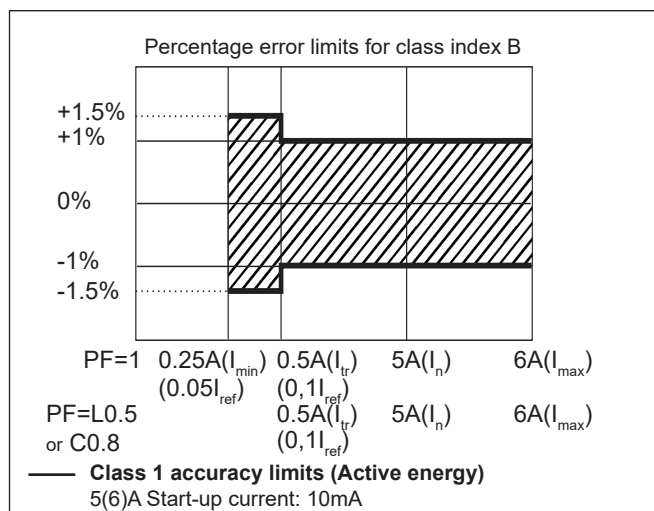

kvarh, accuracy (RDG) depending on the current

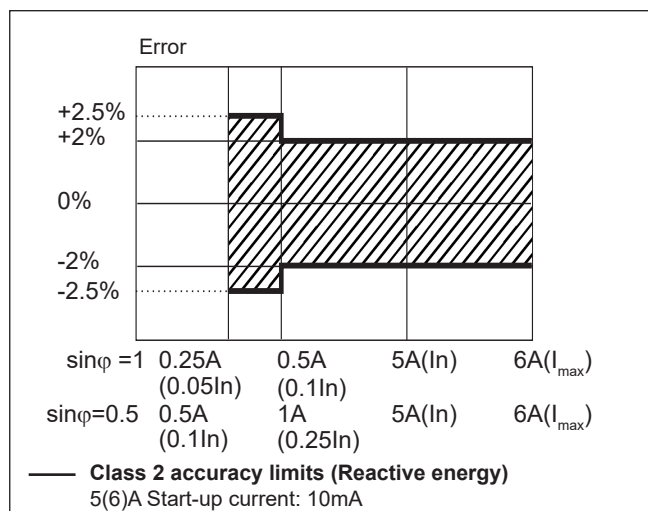

Measurement accuracy according to IEC/EN61557-12 (MID versions)

Active power

Performance class 1

Active energy

Performance class 2

Display pages

1 st row	2 nd row	3 rd row	“Full” mode	“Easy” mode	Note
kWh+ (imported)		kW system	X	X	In case of Measurement set to “A”, total energy without considering the current direction.
kWh- (exported)		kW system	X	X	Only with Measurement set to “B”
kWh+ (imported)		V L-L system	X	X	
kWh+ (imported)		V L-N system	X	X	
kWh+ (imported)		PF system	X		
kWh+ (imported)		Hz	X		
kvarh+ (imported)		Kvar system	X	X	In case of Measurement set to “A”: total positive reactive energy without considering the current direction.
kvarh- (exported)		Kvar system	X	X	Only with Measurement set to “B”
kWh+ (imported)		kVA system	X		
kWh+ (imported)	kWdmd peak	kWdmd	X		
kWh (t1)	“t1”	kW system	X	X	Only relevant to kWh+, with Tariff menu set to ON.
kWh (t2)	“t2”	kW system	X	X	Only relevant to kWh+, with Tariff menu set to ON.
kWh L1	kWh L2	kWh L3	X		In case of Measurement set to “A”, total energy without considering the current direction. In case of Measurement set to “B”, only imported energy.
kVA L1	kVA L2	kVA L3	X		
kvar L1	kvar L2	kvar L3	X		
PF L1	PF L2	PF L3	X		
V L1-N	V L2-N	V L3-N	X		
V L1-2	V L2-3	V L3-1	X		
run hour meter		An	X		
A L1	A L2	A L3	X	X	
kW L1	kW L2	kW L3	X		

X= available

Additional available information on the display

Page	Display	Description
Info 1	YEAr (2015)	Year of production
Info 2	SErIAL n (dddnnnA)	Serial number (ddd= day of the year; nnn=progressive number; A= production line, internal use only)
Info 3	rEVIslon (A.01)	Firmware revision
Info 4	PuLS LEd	Pulse rate of front LED (pulse/kWh)
P3	SYStEM	System type
P4	CT ratio	current transformer ratio
P5	VT ratio	voltage transformer ratio
P6	MEASurE (only X option)	Measurement type
P7	InStALL	Wrong connection detection function
P8	P Int	Integration time for Wdmd calculation
P9	ModE	Set of variables on display
P10	tArIFF	Tariff enabling (and current tariff if enabled)
P11	HoME (only X option)	Selected home page
P12-1	PuLSE (O1 option)	Selection of pulse ON duration of output
P12-2	PuLrAtE (O1 option)	Selection of the pulse rate of output
P13	PrI Add (M1 option)	M-Bus primary address
P14	AddrESS (S1 option)	Modbus serial address
P15	bAud (M1 or S1)	M-Bus or Modbus baud rate
P16-1	PARItY (S1)	Modbus parity
P16-2	StoP blt (S1)	Stop bit (in case of No parity only)
Info 5	Secondary address (M1)	M-Bus secondary address

Wiring diagrams

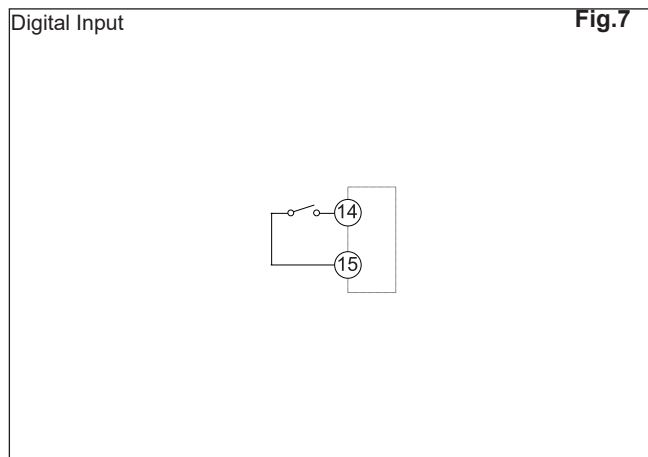
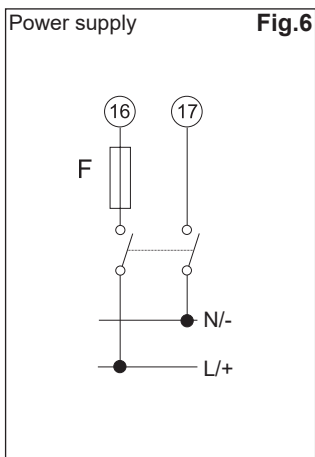
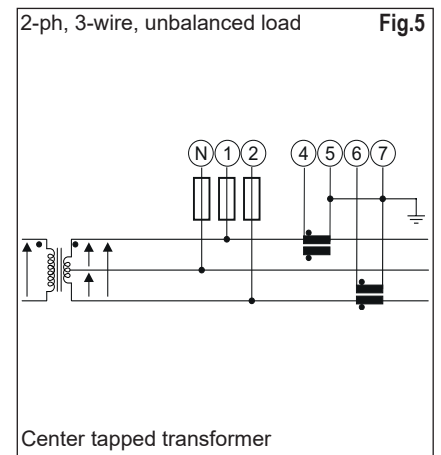
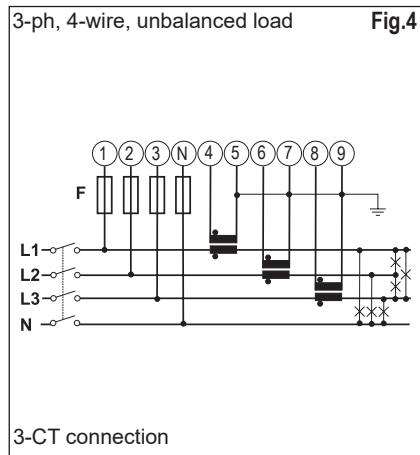
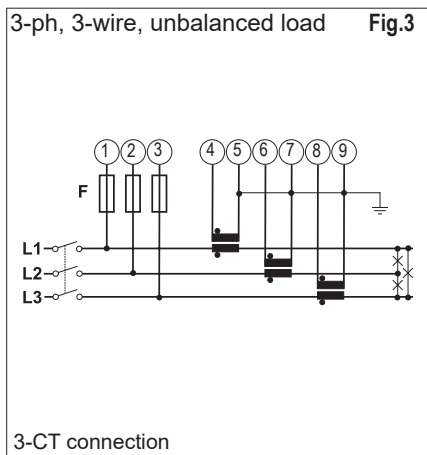
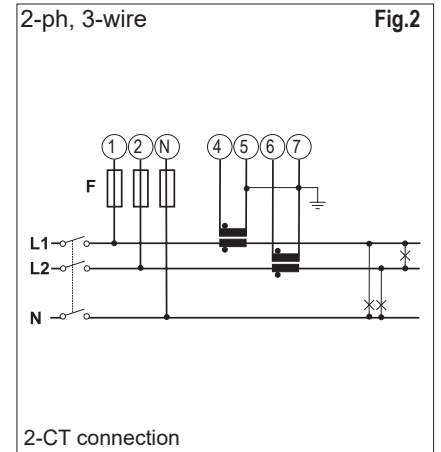
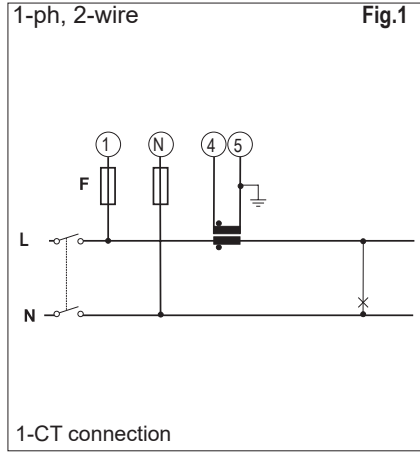
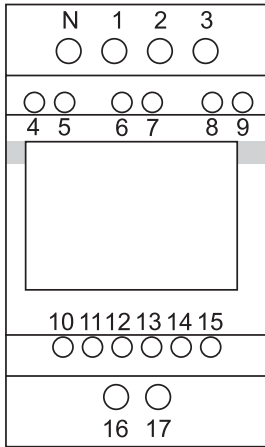

Wiring diagrams (cont.)

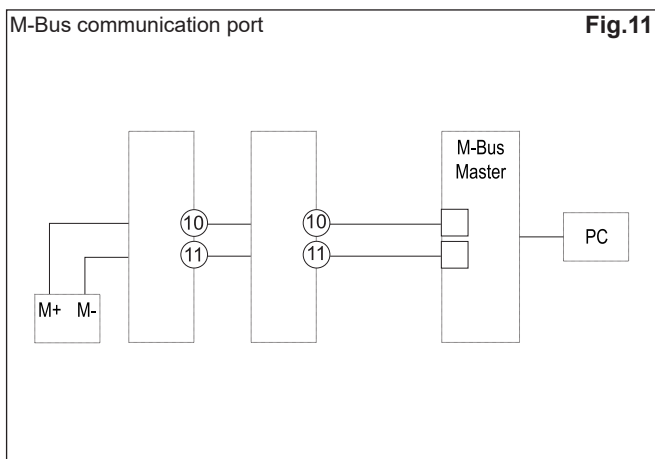
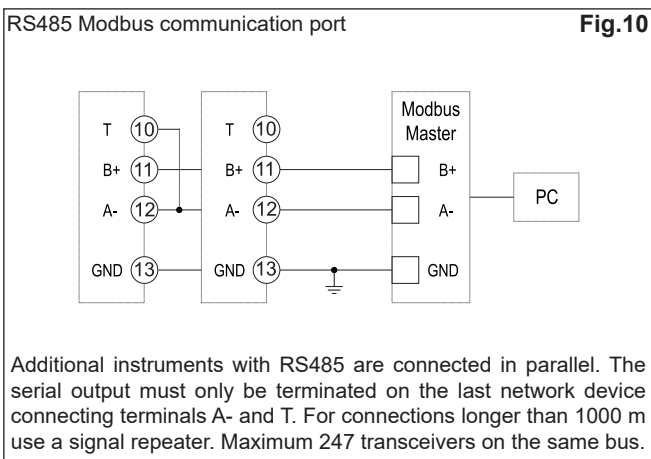
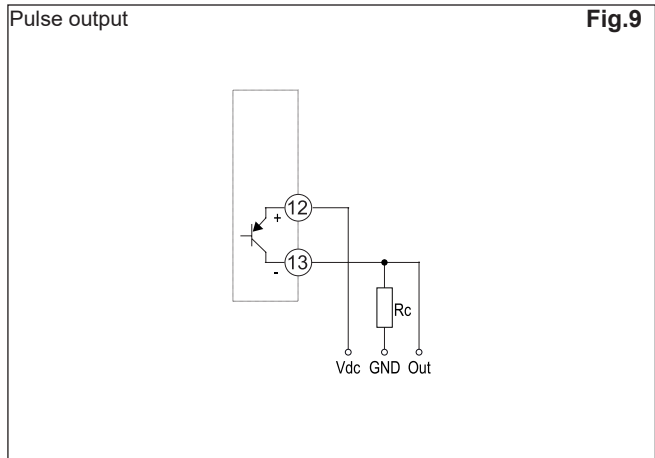
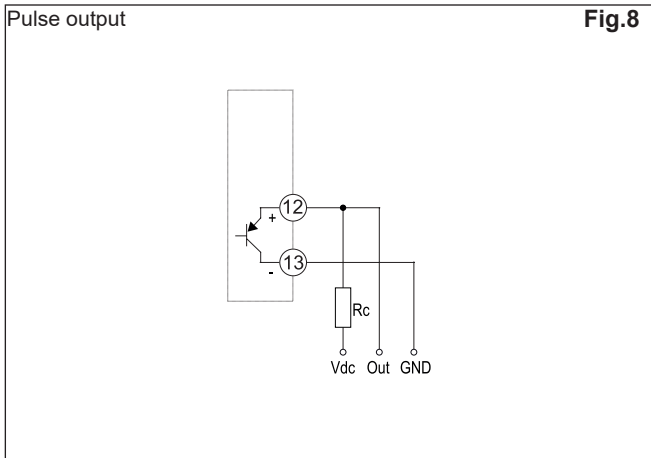

Front panel description

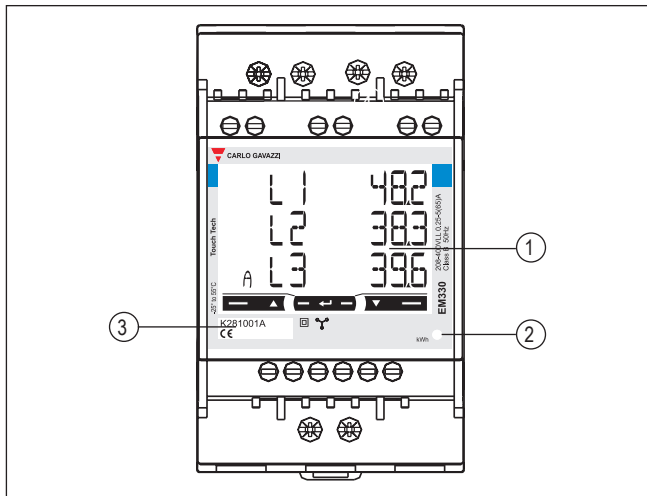

1. **Display**
Backlit LCD display with touch key-pad.
2. **LED**
LED proportional to kWh reading
3. **Serial number**
Area reserved to serial number and MID-relevant data in PF versions

Dimensions

