

Energy Management Energy Transducer Type ET112

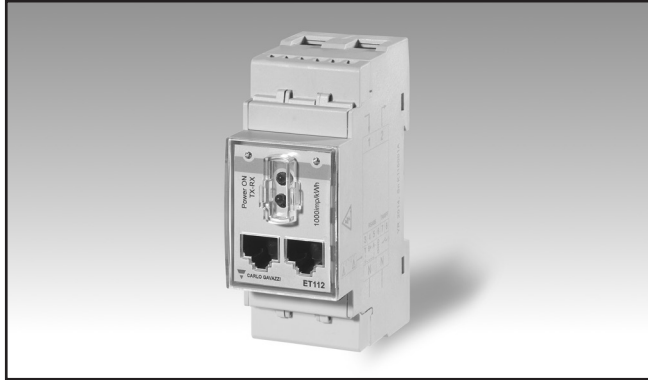

- Single phase energy transducer
- Class 1 (kWh) according to EN62053-21
- Accuracy $\pm 0.5\%$ RDG (current/voltage)
- Direct current measurement up to 100AAC
- Energy measurement: kWh and kvarh (imported/exported); kWh+ by 2 tariffs
- System variables, kW, kvar, V, A, PF, Hz, kWdmd, kWdmd peak
- Self power supply
- Dimensions: 2-DIN module
- Protection degree (front): IP20
- RS485 Modbus port (screw terminals and RJ45 connection)
- Optical port
- Digital input (for tariff management)
- Easy connection or wrong current direction detection
- Run hour meter

Product description

Single-phase energy transducer. Particularly indicated for active energy metering and for cost allocation in applications up to 100 A (direct connection), with dual tariff management availability. It can measure imported and exported energy or be programmed to consider only the imported one. Housing

for DIN-rail mounting, with IP20 front degree protection. The transducer is provided with RS485 Modbus port (available through screw terminals, dual RJ45 connectors or optical infrared communication port). A run-hour meter is available to link the energy to the relevant working hours.

How to order ET112-DIN AV0 1 X S1 X

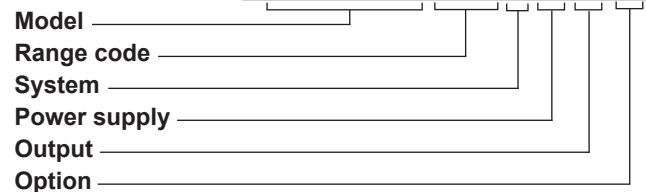

Type Selection

Range code	System	Power supply	Output
AV0: 230VLN AC - 5(100)A (Direct connection)	1: 1-phase 2-wire	X: Self power supply -30% +20% of the rated measuring input voltage, 45 to 65Hz	S1: RS485 Modbus port
AV1: 120VLN AC - 5(100)A (Direct connection). Available on request (MOQ 100 pcs).			

Option

X: none

Input specifications

Rated Inputs		Memory energy storage	
Current type	1-phase loads, direct connection	Energy	10 ¹⁰ cycles. Energy value is saved every time the less significant digit increases.
Current range	5(100)A	Programming parameters	10 ¹⁰ cycles. When a parameter is modified, only the relevant memory cell is overwritten
Nominal voltage	230VLN AC (AV0 option), 120 VLN (AV1 option)		
Accuracy (@25°C ±5°C, R.H. ≤60%, 45 to 65 Hz)		LEDs	
AV1	I _{min} =0.25A; I _b : 5A, I _{max} : 100A; U _n : 120VLN -30% +30%	Right LED	Flashing red light pulses according to EN62052-11, 1000 pulse per kWh (min. period: 90ms)
AV0	I _{min} =0.25A; I _b : 5A, I _{max} : 100A; U _n : 230VLN -30% +20%	Left LED	Fix green light: power-on Blinking red light: power-on and communication in progress
Energies		Current overloads	
Active energy	Class 1 according to EN62053-21	Continuous	100A, @ 50Hz
Reactive energy	Class 2 according to EN62053-23	For 10ms	3000 A
Start-up current:	40mA (AV0, AV1), positive or negative	Voltage Overloads	
	Self-consumption is not measured.	Continuous	1.2 U _n
Start-up voltage	84VLN (AV1), 161VLN (AV0)	For 500ms	2 U _n
Resolution (via serial port)		Input impedance	
Current	0.001 A	Voltage input 230VL-N	1.2Mohm
Voltage	0.1 V	Voltage input 120VL-N	1.2Mohm
Power	0.1 W or var	Current inputs: 5(100) A	< 1.25VA
Frequency	0.1Hz		
PF	0.001		
Energies (positive)	0.1 kWh or kvarh		
Energies (negative)	0.1 kWh or kvarh		
Run hour meter	0.01 h		
Energy additional errors			
Influence quantities	According to EN62053-21		
Temperature drift	≤200ppm/°C		
Sampling rate	4096 samples/s @ 50Hz 4096 samples/s @ 60Hz		
Max. and Min. data values			
Energies	Max. 99 999 999 Min. 0.01		
Variables	Max. 9999 Min. 0.01		
Run hour meter	Max 999 999.99 Min 0.01		

Digital input specifications

Digital inputs	Free of voltage contact	Overload	In case a voltage is erroneously applied to the digital input, the input is not damaged up to 30 VAC/DC.
Function	Tariff management (switch between t1-t2)		
Number of inputs	1		
Contact measurement voltage	5 V		
Contact resistance	100kohm, open contact		
Input impedance	1kohm		

Output specifications

RS485 serial port	RS485 by screw connection or RS485 by standard female RJ45 connectors (not shielded). For communication of measured data, programming parameters	Baud rate	9.6, 19.2 kbaud, even or no parity
Function	ModBus RTU (slave function)	Address	1
Protocol		Data refresh time	1 sec
Baud rate	9.6, 19.2, 38.4, 57.6, 115.2 kbaud, even or no parity,	Read command	50 words available in 1 read command
Address	1 to 247 (default: 01)	Optical port LEDs	6.5 mm
Driver input capability	1/8 unit load. Maximum 247 transceivers on the same bus.	LED axial distance	- Upper LED is a receiver (from the master to the transducer
Data refresh time	1sec	LED function	- Lower LED is a transmitter (from the trasducer to the master).
Read command	50 words available in 1 read command		
RJ45 pin-out	According to Modbus standard: A- (pin5), B+ (pin4), GND (pin8)		
Other ports	All the Modbus ports (screw terminals, two RJ45) are in parallel. Only one port at a time can be used.		
Optical port			
Description	Frontal bi-directional infrared optical coupling with CG optical reader device "Opto-prog"		
Function	For remote communication of measured data and setting of programming parameters		
Protocol	ModBus RTU (slave function)		

General specifications

Operating temperature	-25 to +65 °C, indoor, (R.H. from 0 to 90% non-condensing @ 40°C)	Standard compliance	EN62052-11 EN62053-21
Storage temperature	-30°C to +80°C (R.H. < 90% noncondensing @ 40°C)	Approvals	CE
Overvoltage category	Cat. III	Connections	Measuring inputs: max. 25 mm ² , min. 5 mm ² with/without metallic cable ferrule; Max. screw tightening torque: 2.8 Nm 1.5 mm ² , Min./Max. screws tightening torque: 0.5 Nm
Insulation (for 1 minute)	4000 VAC RMS between measuring inputs and digital/serial output (see table) 4000 VAC RMS	Other terminals	
Dielectric strength	4000 VAC RMS for 1 minute	Housing	35 x 63 x 90 mm Noryl, self-extinguishing: UL 94 V-0 Included
EMC	According to EN62052-11 15kV air discharge;	Dimensions (WxHxD)	
Electrostatic discharges	Test with current: 10V/m from 80 to 2000MHz;	Material	DIN-rail
Immunity to irradiated electromagnetic fields	Test without any current: 30V/m from 80 to 2000MHz;	Sealing covers	
Burst	On current and voltage measuring inputs circuit: 4kV	Mounting	IP20 IP20
Immunity to conducted disturbances	10V/m from 150KHz to 80MHz	Protection degree	
Surge	On current and voltage measuring inputs circuit: 4kV;	Front	Approx. 160 g (packing included)
Radio frequency	According to CISPR 22	Screw terminals (cable inputs)	
		Weight	

Power supply specifications

Self power supply		Power consumption	≤ 1.0W, ≤ 8VA
AV0	230VAC VL-N, -30% +20% 50/60Hz		
AV1	120VAC VL-N, -30% +30% 50/60Hz		

Insulation (for 1 minute) between inputs and outputs

	Measuring input	Serial output	Digital input
Measuring input	-	4 kV	4 kV
Serial output	4 kV	-	0 kV
Digital input	4 kV	0 kV	-

Accuracy (according to 62053-21 and EN62053-23)

kWh, accuracy (RDG) depending on the current

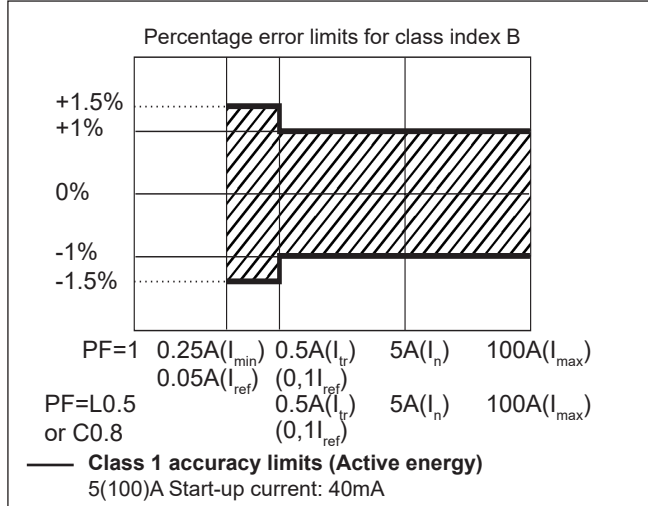

kvarh, accuracy (RDG) depending on the current

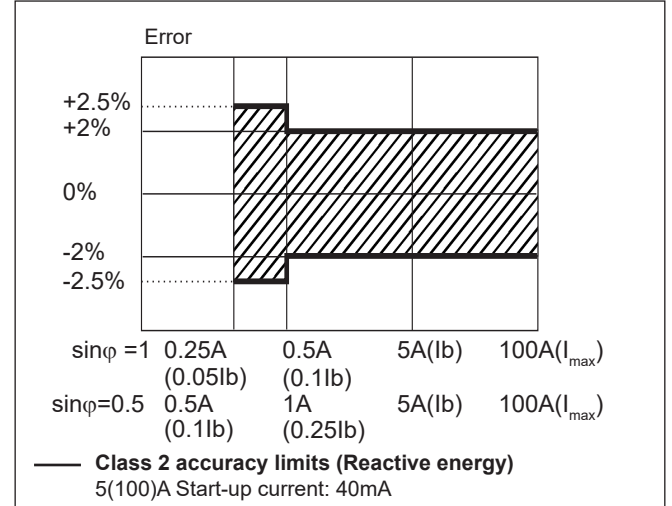

Available variables

1	kWh+ (imported)
2	kWh- (exported)
3	kWh (t1 and t2)
4	kW
5	kW dmd
6	kW dmd peak
7	kvar
8	kVA
9	V
10	A
11	PF
12	Hz
13	Run hour meter

List of programming parameters

Menu name and description		Range	Default setting
Measure	Measurement type (A=easy connection; B=bidirectional, imported and exported energy). Not available in PFA and PFB versions (MID)	A; b	A
P int	Integration time for Wdmd calculation	1 to 30 min	1
Tariff	Tariff enabling	Yes/No	No
Address	Modbus serial address	1 to 247	01
Kbaud	Modbus baud rate	9.6; 19.2; 38.4; 57.6, 115.2 kbps	9.6
ParITY	Modbus parity	No/even	No
RESET	Allow the reset of tariff meters and W dmd peak and of the kWh/kvarh partial meter available only via serial communication	Yes/No	No

Wiring diagrams

Note: fuses F of 315 mA, if required by local law.

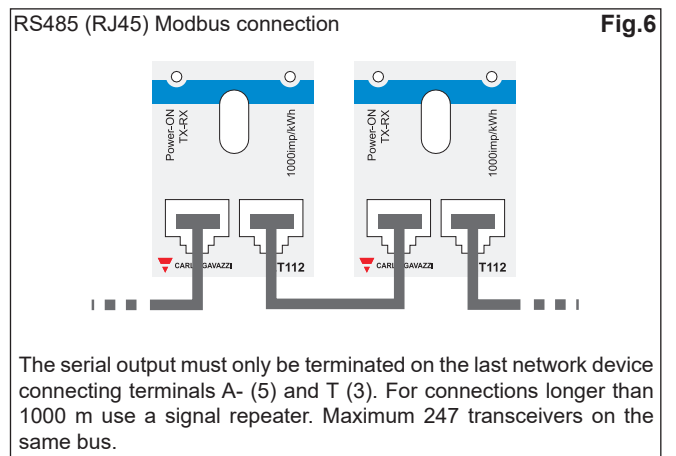
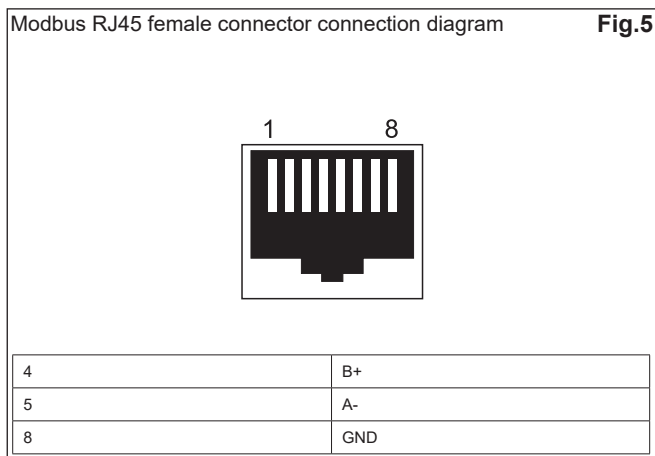
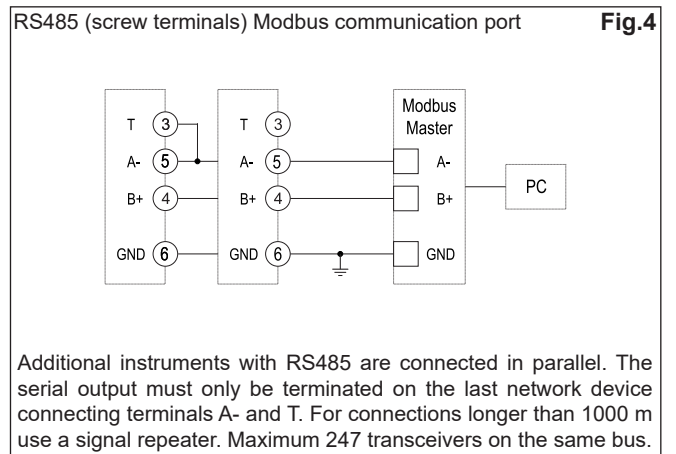
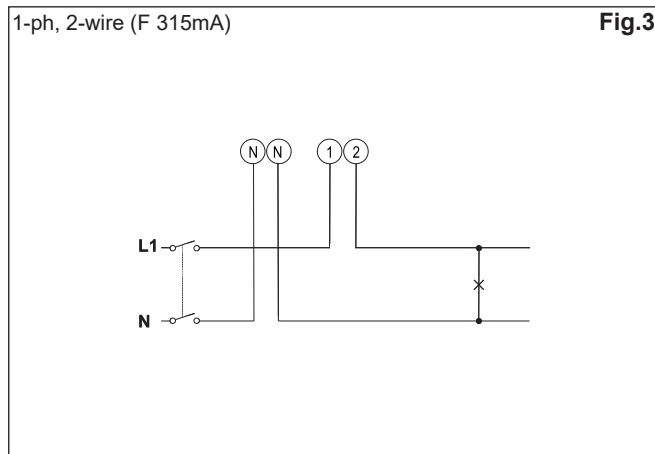
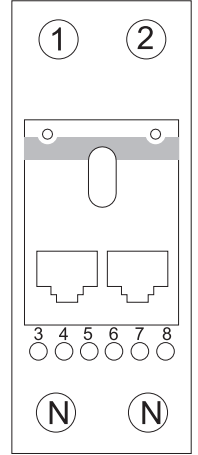
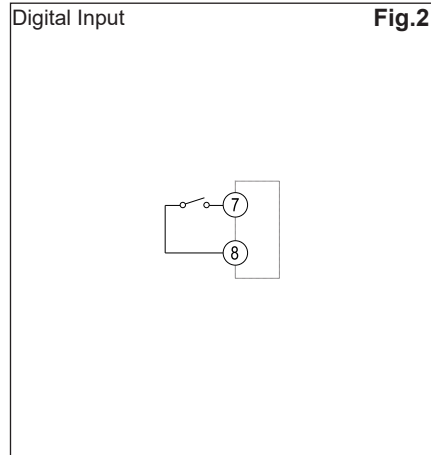
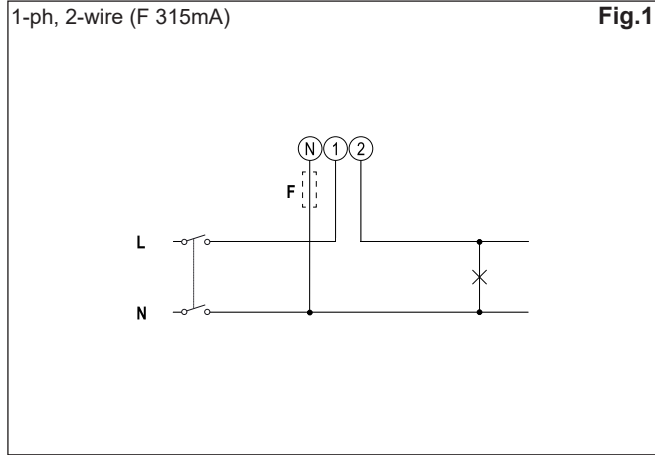

Front panel description

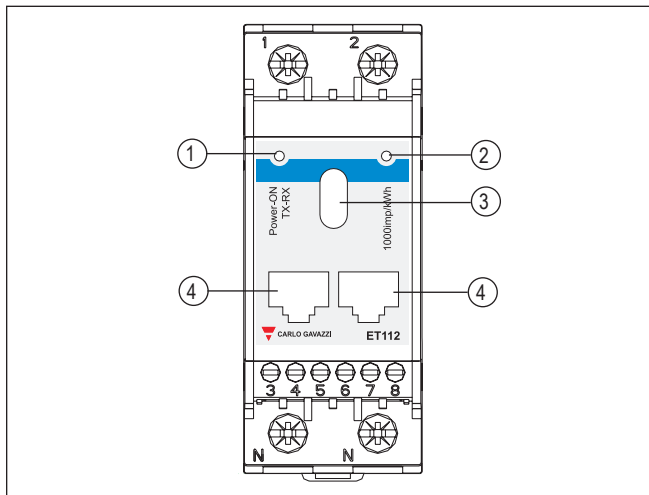

1. **LED**
Power-ON LED with communication indication (when blinking)
2. **LED**
LED proportional to kWh reading
3. **Optical port**
Optical port for data transmission or programming
4. **RJ45 Modbus RTU ports (RS485)**
Modbus ports for fast bus connection. The ports are in parallel. The screw terminals can be used as well (same Modbus port).

Dimensions (mm)

