

BATTERY FUSE



 etigroup
www.etigroup.eu



BATTERY
FUZE

BECAUSE EVERY
SECOND COUNTS

**NH Fuse-links with
gBat Characteristic**

ETI
SWITCH TO
A SAFE FUTURE

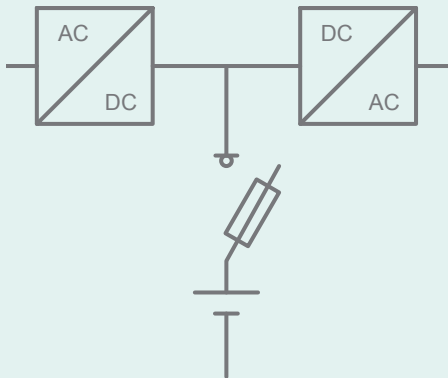
Battery Storage Fuse Selection



Short circuit current

- Short circuit current depending on battery model, type and capacity, low compared to operating current
- Short circuit current has to be interrupted in <5 seconds
- Required steep characteristics: protection with Battery fuse-link required!

Operating current

- Operating current depends on battery storage specification
- Battery operation: voltage of DC link circuit decreases to the final discharge voltage
- Consider maximum current at final discharge voltage for fuse-link selection

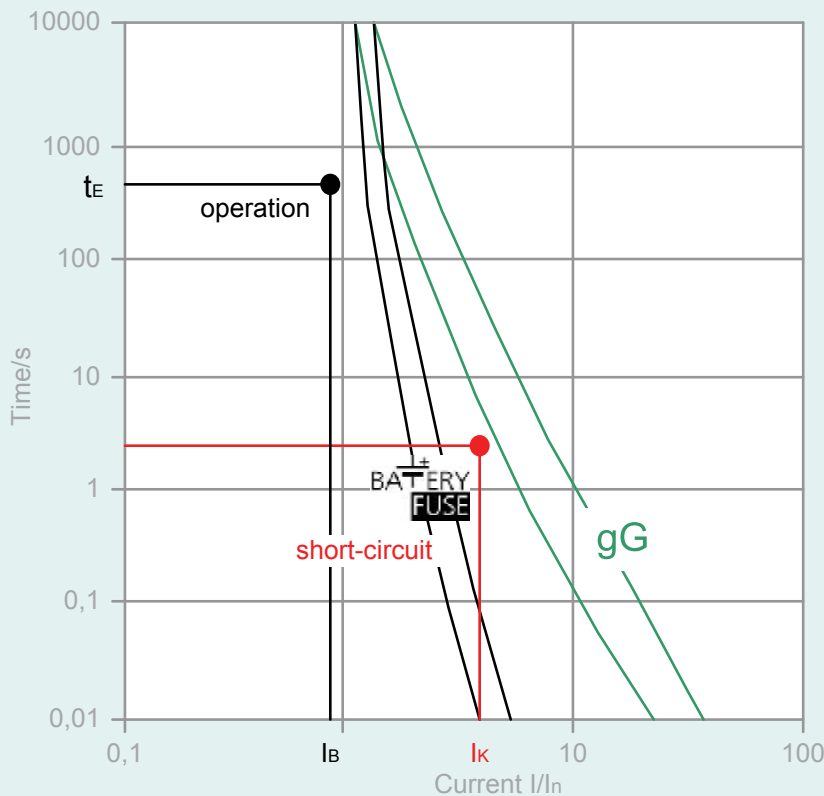

In accordance with IEC 60269-7

Short circuit point (I_k)

- Short circuit current depending on battery model and type
- Manufacturer datasheets to include short circuit current according to IEC896
- Operating point has to be in adequate distance below the curve
- Short-circuit point has to be above the range of tolerance of the curve

Operating point (t_E/I_B)

- maximum operating current I_B has to be calculated from battery storage true power and final discharge voltage U_E : $I_B = P_w/U_E$
- t_E is the back-up time of battery storage system

When choosing fuse switch disconnector consider fuse-link power dissipation!

$$P_d(I_B) < P_y$$

Power dissipation of fuse-link at maximal operating current (I_B):

$$P_d(I_B) = (I_B/I_n)^2 \times P_d(I_n)$$

I_B - maximal operating current

$P_d(I_B)$ - power dissipation of fuse-link at maximal operating current

$P_d(I_n)$ - power dissipation of fuse-link at nominal current

P_y - maximal permissible fuse-link power dissipation mounted in fuse switch disconnector

Low Power Dissipation and Fast Characteristic in Time Range of 5s!

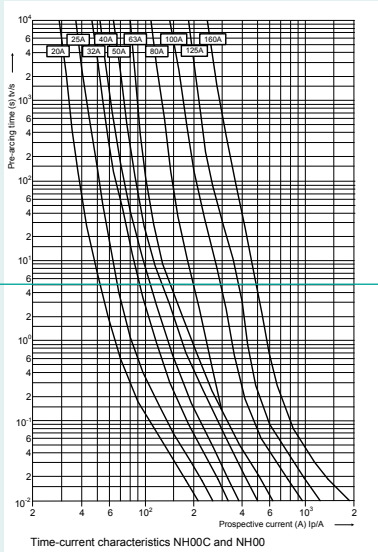

Discharge	-20~60°C
Charge	-10~60°C
Storage	-20~60°C
Max. Discharge Current 77°F(25°C)	1000A(5s)
Short Circuit Current	3300A
Charge Methods: Constant Voltage Charge 77°F(25°C)	
Cycle use	14.4-14.7V
Maximum charging current	60A
Temperature compensation	-30mV/°C

5s

I_k

Better protection of battery cells on overheating in case of short circuit comparable to standard gG characteristic

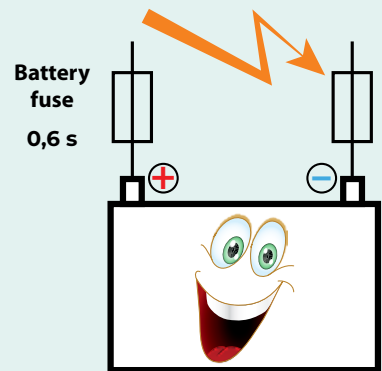
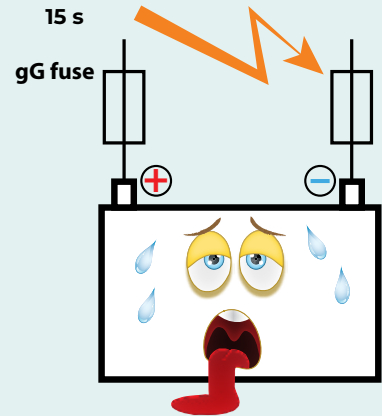
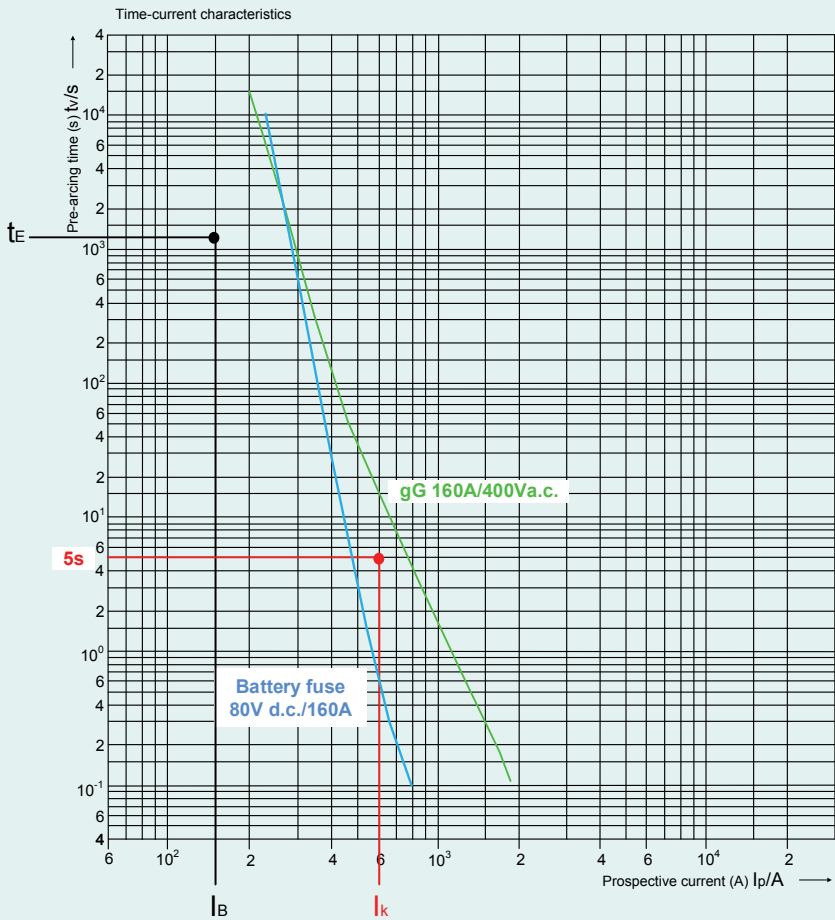

NH gBat fuse-link 80V d.c.

General characteristics

Rated voltage	80V d.c., L/R=10ms
Breaking capacity	50kA d.c..
Standard	IEC 60269-7
Application	Battery protection
Fuse base	NH00C, NH00: 004123001 PK00 NH1C, NH1: 004123100 PK1

NH gBat fuse-link 80V d.c.

Size	I _n [A]	Standard indicator	Power dissipation [W]	Power dissipation 0,7xI _n [W]	Pre-arcing Joule integral [A ² s]	Operating Joule integral [A ² s]	g	Box
00C pic. 1	20	004110075	4,6	2	360	414	125	3/120
	25	004110076	5,8	2,6	710	817		
	32	004110077	6,6	3	920	1.058		
	40	004110078	9,4	4,2	1.440	1.656		
	50	004110079	11,1	5	2.820	3.243		
00 pic. 1	63	004110080	11,7	5,2	4.160	4.784	173	3/90
	80	004110081	10,4	4,7	4.670	5.371		
	100	004110082	11,1	5	9.360	10.764		
	125	004110083	13,4	6	14.750	16.963		
	160	004110084	15,5	7	27.880	32.062		
1C pic. 2	20	004110085	6,3	2,8	360	414	233	3/45
	25	004110086	7,3	3,3	710	817		
	32	004110087	9	4	920	1.058		
	40	004110088	11,2	5	1.440	1.656		
	50	004110089	14,5	6,5	2.820	3.243		
	63	004110090	16,8	7,5	4.160	4.784		
	80	004110091	11,4	5,1	4.670	5.371		
1 pic. 3	100	004110092	12	5,4	9.360	10.764	430	3/24
	125	004110093	14,8	6,6	14.750	16.963		
	160	004110094	17,6	7,9	27.880	32.062		
	200	004110095	26,6	11,9	41.990	48.289		
	250	004110096	31	13,9	81.000	93.150		



Picture 1

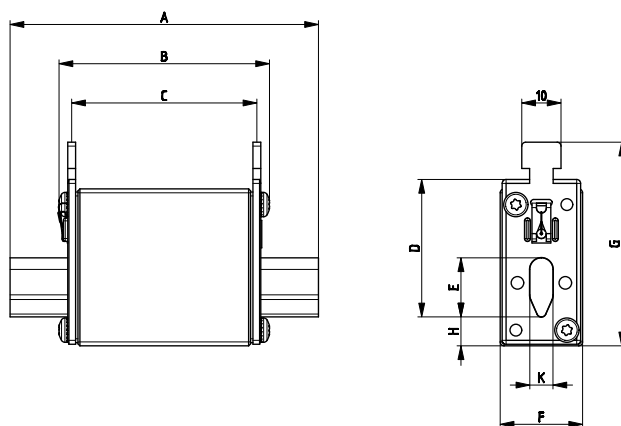

Picture 2

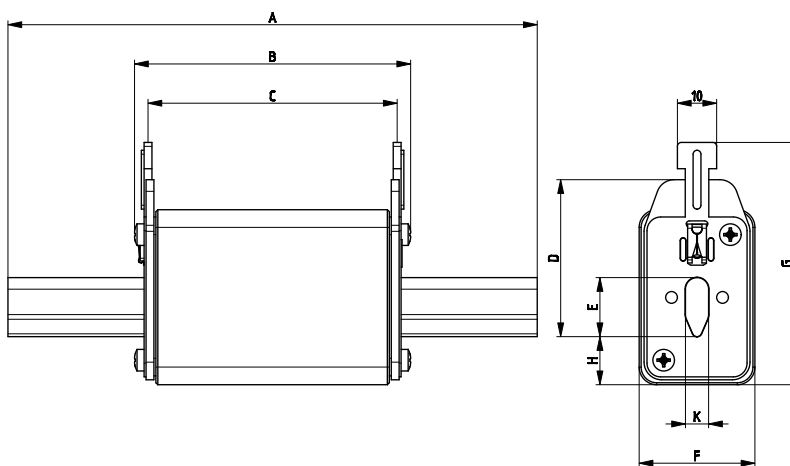

Picture 3

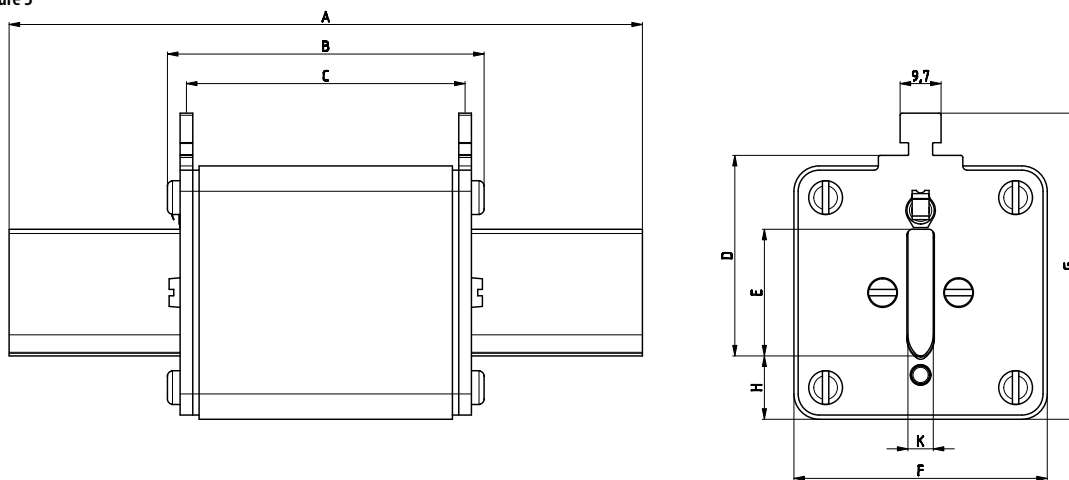

Size	A	B	C	D	E	F	G	H	K
00 C	79	53	47	35	15	21	52	7,5	6
00	79	53	47	35	15	28	56	12	6
1 C	135	68	65	40	15	28	61	12	6
1	135	72	65	40	20	46	65	14	6